

HMMC-5021, HMMC-5022, HMMC-5026, QMMC-5002

GaAs MMIC Traveling Wave Amplifier

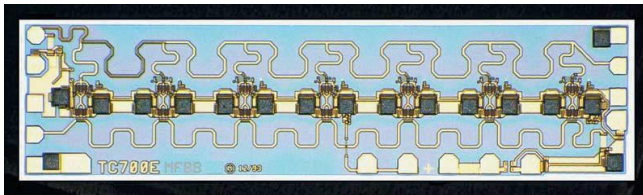

Description

The HMMC-5021/22/26/QMMC-5002 is a broadband GaAs MMIC traveling wave amplifier designed for high gain and moderate output power over the full 2 to 26.5 GHz frequency range. Seven MESFET cascode stages provide a flat gain response, making the HMMC-5021/22/26/QMMC-5002 an ideal wideband gain block. Optical lithography is used to produce gate lengths of $\approx 0.4 \mu\text{m}$. The HMMC-5021/22/26/QMMC-5002 incorporates advanced MBE technology, Ti-Pt-Au gate metallization, silicon nitride passivation, and polyimide for scratch protection.

Highlights

- Wide-frequency range: 2 to 26.5 GHz
- High gain: 9.5 dB
- Gain flatness: ± 0.75 dB
- Return loss:
 - Input: -14 dB
 - Output: -13 dB
- Low-frequency operation capability: < 2 GHz
- Gain control: 35 dB dynamic range
- Moderate power:
 - 20 GHz:
 - $P_{-1 \text{ dB}}$: 18 dBm,
 - P_{sat} : 20 dBm
 - 26.5 GHz:
 - $P_{-1 \text{ dB}}$: 15 dBm
 - P_{sat} : 17 dBm

Absolute Maximum Ratings¹

Symbol	Parameters/conditions	Minimum	Maximum	Units
V _{DD}	Positive drain voltage		8.0	Volts
I _{DD}	Total drain current		250	mA
V _{G1}	First gate voltage	-5	0	Volts
I _{G1}	First gate current	-9	+5	mA
V _{G2} ²	Second gate voltage	-2.5	+3.5	Volts
I _{G2}	Second gate current	-7		mA
P _{DC}	DC power dissipation		2.0	Watts
P _{in}	CW input power		23	dB
T _{ch}	Operating channel temp.		+150	°C
T _{case}	Operating case temp.	-55		°C
T _{stg}	Storage Temperature	-65	+165	°C
T _{max}	Maximum assembly temp. (for 60 seconds max.)		+300	°C

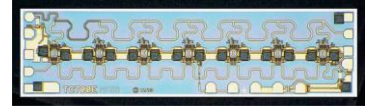

Chip size:
2980 × 770 μm (117.3 × 30.3 mils)

Chip size tolerance:
±10 μm (±0.4 mils)

Chip thickness:
127 ± 15 μm (5 ± 0.6 mils)

Pad dimensions:
75 × 75 μm (2.95 × 2.95 mils),
or larger

1. Operation in excess of any one of these conditions may result in permanent damage to this device.
T_A = 25 °C except for T_{ch}, T_{stg}, and T_{max}.
2. Minimum voltage on V_{G2} must not violate the following: V_{G2} (min) > V_{DD} - 9 volts.

DC Specifications/Physical Properties¹ (Applies to all Part Numbers)

Symbol	Parameters/conditions	Min.	Typ.	Max	Units
I_{DSS}	Saturated drain current ($V_{DD} = 7.0$ V, $V_{G1} = 0.0$ V, $V_{G2} =$ open circuit)	115	180	250	mA
V_p	First gate pinch-off voltage ($V_{DD} = 7.0$ V, $I_{DD} = 16$ mA, $V_{G2} =$ open circuit)	-3.5	-1.5	-0.5	volts
V_{G2}	Second gate self-bias voltage ($V_{DD} = 7.0$ V, $V_{G1} = 0.0$ V)		2.1		volts
$I_{DSOFF}(V_{G1})$	First gate pinch-off current ($V_{DD} = 7.0$ V, $V_{G1} = -3.5$ V, $V_{G2} =$ open circuit)		4		mA
$I_{DSOFF}(V_{G2})$	Second gate pinch-off current ($V_{DD} = 5.0$ V, $V_{G1} = 0.0$ V, $V_{G2} = -3.5$ V)		8		mA
θ_{ch-bs}	Thermal resistance ($T_{backside} = 25$ °C)		36		°C/W

1. Measured in wafer form with $T_{chuck} = 25$ °C. (except θ_{ch-bs}).

RF Specifications

($V_{DD} = 7.0$ V, $I_{DD}(Q) = 150$ mA, $Z_{in} = Z_o = 50$ Ω)¹

Symbol	Parameters/conditions	HMMC-5021			HMMC-5022		HMMC-5026			QMMC-5002		Units
		Typ.	Min	Max	Min	Max	Typ.	Min	Max	Min	Max	
BW	Guaranteed Bandwidth ²		2	22	2	22		2	26.5	2	22	GHz
S_{21}	Small signal gain	9.5			8	12	9	7	12	9.5 ³	14 ³	dB
ΔS_{21}	Small signal gain flatness	± 0.75				± 1	± 0.75		± 1.5		$\pm 0.75^3$	dB
$RL_{in(min)}$	Minimum input return loss	16			15		14	12		15		dB
$RL_{out(min)}$	Minimum output return loss	13			13		13	10		13		dB
Isolation	Minimum reverse isolation	32			23		30	23		23		dB
$P_{-1\text{ dB}}$	Output power at 1 dB gain compression	18			15		15	12		15		dBm
P_{sat}	Saturated output power	20			17		17	14	18	17		dBm
$H_{2(max)}$	Max. second harm. ($2 < f_o < 20$), $[P_o(f_o) = 1/\text{dBm}$ or $P_{-1\text{dB}}$, whichever is less]	-25				-20	-25		-20		-20	dBc
$H_{3(max)}$	Max. third harm. ($2 < f_o < 20$), $[P_o(f_o) = 1/\text{dBm}$ or $P_{-1\text{dB}}$, whichever is less]	-34				-20	-34		-20		-20	dBc
NF	Noise Figure	8					10					dB

- Small-signal data measured in wafer form with $T_{chuck} = 25$ °C. Large-signal data measured on individual devices mounted in an Keysight 83040 Series Modular Microcircuit Package @ $T_A = 25$ °C.
- Performance may be extended to lower frequencies through the use of appropriate off-chip circuitry. Upper -3 dB corner frequency ~ 29.5 GHz.
- These specifications are applicable to 2.0 to 18 GHz only.

Applications

The HMMC-5021/22/26/QMMC-5002 Series of traveling wave amplifiers are designed for use as general-purpose wideband gain blocks in communication systems and microwave instrumentation. They are ideally suited for broadband applications requiring a flat gain response and excellent port matches over a 2 to 26.5 GHz frequency range. Dynamic gain control and low-frequency extension capabilities are designed into these devices.

It is characteristic of traveling wave amplifiers that S_{22} tends to 0 dB and greater out of band. This is the design trade-off for the broadband performance of TWAs. As a consequence, TWAs are not necessarily unconditionally stable out of band. This means that if a TWA is followed by a reflective low-pass filter, oscillations can occur. This phenomenon is exacerbated by low temperature where the gain is higher. More data will follow on individual devices.

Biasing and Operation

These amplifiers are biased with a single positive drain supply (V_{DD}) and a single negative gate supply (V_{G1}). The recommended bias conditions for the HMMC-5021/22/26/QMMC-5002 are $V_{DD} = 7.0$ V, $I_{DD} = 150$ mA for best overall performance. To achieve this drain current level, V_{G1} is typically biased between -0.2 V and -0.5 V. No other bias supplies or connections to the device are required for 2 to 26.5 GHz operation. See Figure 3 for assembly information.

The auxiliary gate and drain contacts are used only for low-frequency performance extension below ≈ 1.0 GHz. When used, these contacts must be AC coupled only. (Do not attempt to apply bias to these pads.)

The second gate (V_{G2}) can be used to obtain 35 dB (typical) dynamic gain control.

For normal operation, no external bias is required on this contact and its self-bias voltage is $\approx +2.1$ V. Applying an external bias between its open-circuit voltage and -2.5 volts will adjust the gain while maintaining a good input/output port match.



Additional References

2–26.5 GHz Variable Gain Amplifier Using TC700 and TC701 GaAs MMIC Components, Technical Overview (5991-3543EN)

TC700/702 Traveling Wave Amplifier Environmental Data, Technical Overview (5991-3553EN)

TC700 S-Parameters Performance as a Function of Bonding Configuration, Technical Overview (5991-3552EN)

GaAs MMIC TWA, Users Guide (5991-3545EN)

Assembly Techniques

Solder die-attach using a flux-less AuSn solder preform is the recommended assembly method. Gold thermosonic wedge bonding with 0.7 mil diameter Au wire is recommended for all bonds. Tool force should be 22 ± 1 gram, stage temperature should be 150 ± 2 °C, and ultrasonic power and duration should be 64 ± 1 dB and 76 ± 8 msec, respectively. The bonding pad and chip backside metallization is gold.

GaAs MMICs are ESD sensitive. ESD preventive measures must be employed in all aspects of storage, handling, and assembly.

MMIC ESD precautions, handling considerations, die attach and bonding methods are critical factors in successful GaAs MMIC performance and reliability.

Keysight application note, *GaAs MMIC ESD, Die Attach and Bonding Guidelines* (5991-3484EN) provides basic information on these subjects.

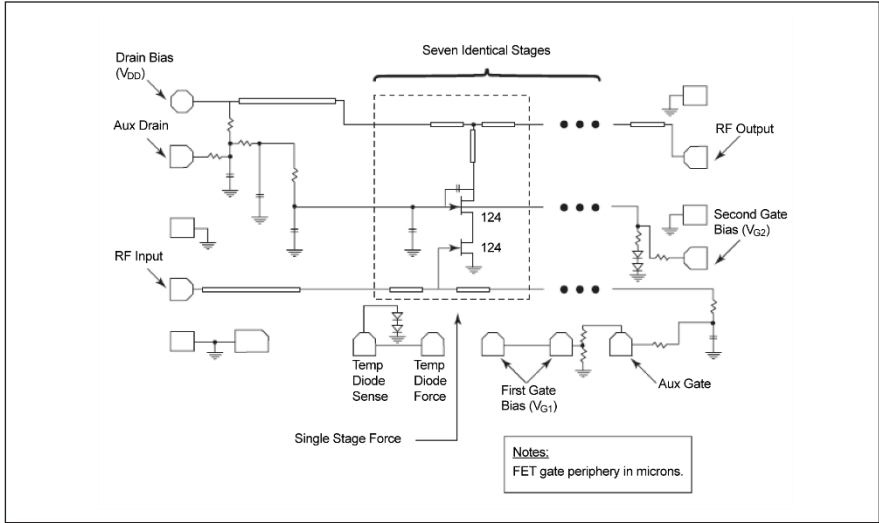

Figure 1. Schematic.

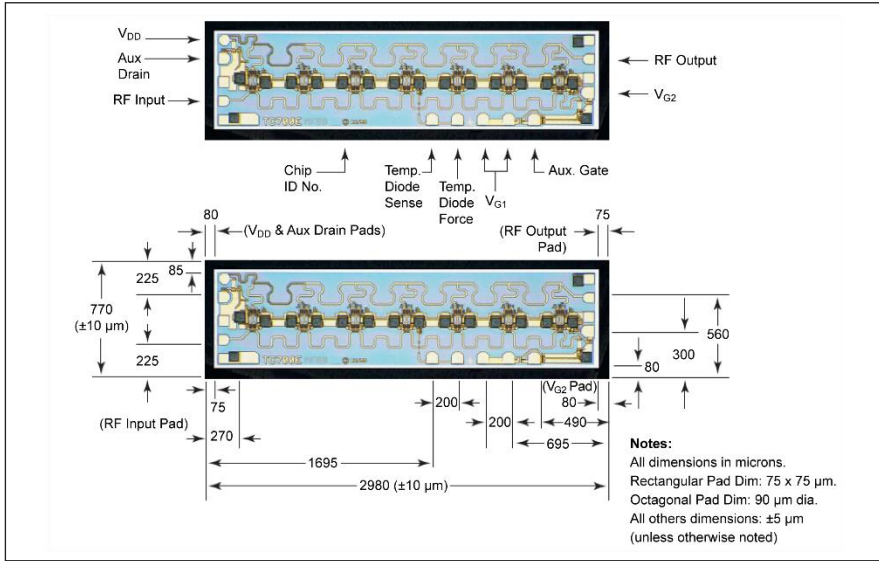

Figure 2. Bonding pad locations.

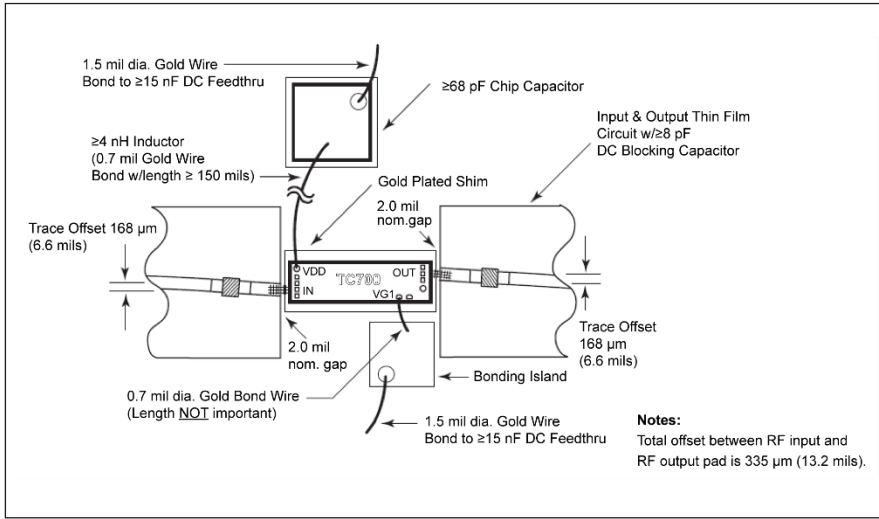

Figure 3. Assembly diagram (For 2 – 26 GHz operation).

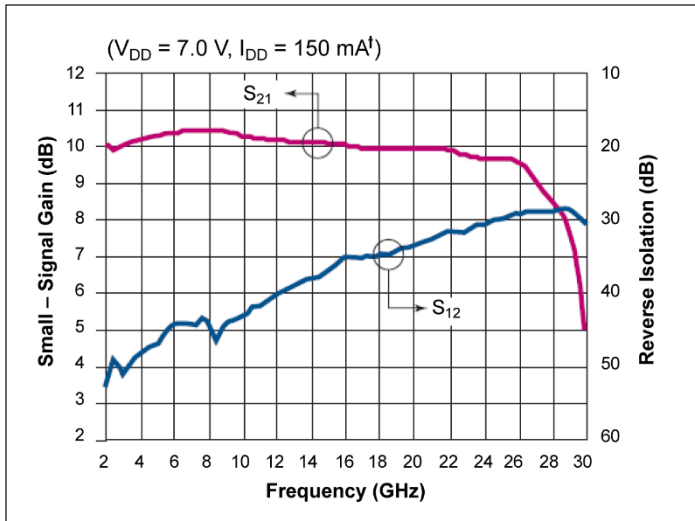

Figure 4. Sample Gain and reverse isolation vs frequency.

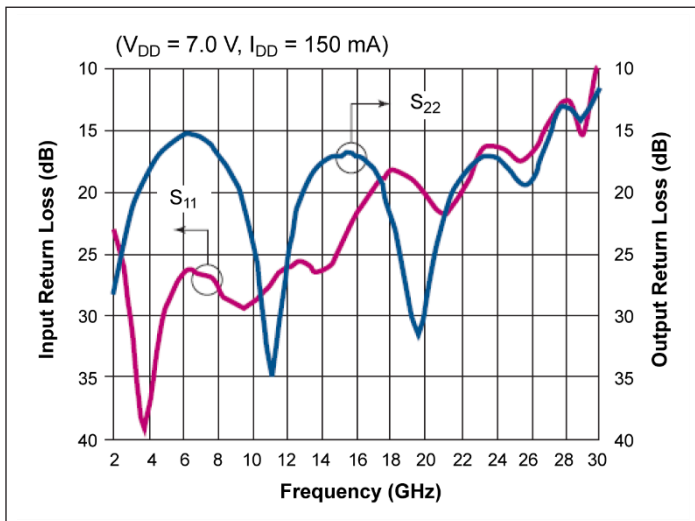

Figure 5. Sample input and output return loss vs frequency.

Sample S-Parameters¹

($T_{\text{chuck}} = 25^\circ \text{C}$, $V_{\text{DD}} = 7.0 \text{V}$, $I_{\text{DD}} = 150 \text{mA}$, $Z_{\text{in}} = Z_{\text{out}} = 50 \Omega$)

Freq. (GHz)	S ₁₁			S ₁₂			S ₂₁			S ₂₂		
	dB	Mag	Ang	dB	Mag	Ang	dB	Mag	Ang	dB	Mag	Ang
2.0	-22.6	0.074	-174.1	-53.1	0.0022	167.3	-10.1	3.183	123.6	-28.9	0.036	77.3
3.0	-30.6	0.030	130.4	-51.0	0.0028	120.1	-10.0	3.173	102.1	-21.6	0.083	64.1
4.0	-37.8	0.013	-19.8	-48.0	0.0040	95.0	-10.2	3.225	78.2	-18.2	0.124	45.4
5.0	-29.4	0.034	-79.9	-46.8	0.0046	67.1	-10.3	3.275	53.5	-16.3	0.153	23.4
6.0	-26.6	0.047	-113.8	-44.4	0.0060	36.0	-10.4	3.303	28.1	-15.4	0.170	2.5
7.0	-26.6	0.047	-137.0	-44.1	0.0062	1.0	-10.3	3.330	2.3	-15.7	0.165	-19.5
8.0	-27.7	0.041	-152.6	-43.4	0.0067	-27.5	-10.5	3.331	-23.8	-17.0	0.141	-40.7
9.0	-29.0	0.035	-149.8	-44.3	0.0061	-31.8	-10.4	3.312	-50.2	-19.2	0.110	-59.7
10.0	-29.0	0.036	-140.8	-43.0	0.0071	-53.6	-10.3	3.282	-76.4	-24.3	0.061	-76.8
11.0	-27.3	0.043	-138.1	-41.6	0.0083	-74.8	-10.2	3.253	-102.5	-35.1	0.018	-32.6
12.0	-26.2	0.049	-141.9	-40.0	0.0100	-96.9	-10.2	3.227	-128.8	-24.6	0.059	21.0
13.0	-25.8	0.052	-148.5	-38.9	0.0113	-120.9	-10.2	3.218	-155.4	-19.7	0.103	2.8
14.0	-26.4	0.048	-143.0	-38.1	0.0125	-145.6	-10.1	3.204	177.8	-17.6	0.132	-21.2
15.0	-24.6	0.059	-131.7	-36.6	0.0148	-169.9	-10.1	3.197	150.4	-17.0	0.141	-44.8
16.0	-21.6	0.083	-133.7	-35.3	0.0172	160.9	-10.0	3.177	122.5	-17.1	0.140	-67.4
17.0	-19.4	0.107	-143.5	-35.0	0.0177	130.6	-10.0	3.149	94.4	-18.5	0.119	-91.8
18.0	-18.3	0.121	-158.7	-34.7	0.0184	105.0	-9.9	3.138	65.9	-21.8	0.081	-116.0
19.0	-18.7	0.116	-172.6	-33.9	0.0201	80.2	-9.9	3.140	36.8	-28.9	0.036	-121.7
20.0	-20.3	0.097	-179.5	-33.3	0.0217	50.7	-10.0	3.151	6.6	-28.5	0.038	-57.0
21.0	-21.8	0.082	-168.3	-32.7	0.0233	22.5	-10.0	3.150	-24.9	-21.7	0.082	-59.1
22.0	-19.9	0.101	-155.3	-31.7	0.0259	-8.4	-9.9	3.126	-57.5	-18.6	0.117	-81.5
23.0	-17.3	0.137	-158.8	-31.4	0.0268	-39.5	-9.8	3.076	-91.0	-17.3	0.137	-103.3
24.0	-16.3	0.153	-169.9	-30.7	0.0291	-71.5	-9.7	3.045	-125.5	-17.3	0.137	-123.8
25.0	-17.1	0.139	-175.4	-30.0	0.0317	-106.2	-9.7	3.045	-162.2	-18.5	0.118	-135.3
26.0	-17.0	0.141	-165.0	-29.2	0.0345	-145.5	-9.6	3.027	157.2	-19.4	0.107	-122.5
26.5	-15.7	0.163	-161.1	-29.0	0.0356	-166.7	-9.5	2.970	135.4	-17.6	0.132	-114.2
27.0	-14.3	0.192	-162.7	-28.9	0.0357	171.7	-9.2	2.876	112.9	-15.3	0.173	-116.0
28.0	-13.2	0.220	-175.7	-28.8	0.0362	126.3	-8.5	2.648	65.8	-12.6	0.233	-138.1
29.0	-14.1	0.197	-176.9	-28.6	0.0371	73.0	-7.7	2.433	10.3	-15.4	0.170	-144.7
30.0	-14.1	0.266	-171.6	-30.8	0.0287	4.8	-4.6	1.689	-61.1	-8.7	0.369	-123.6

1. Data obtained from on-wafer measurements

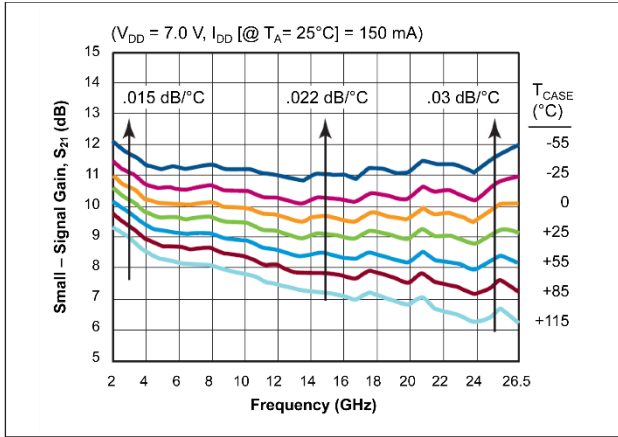

Figure 6. Sample small signal gain vs. temperature.

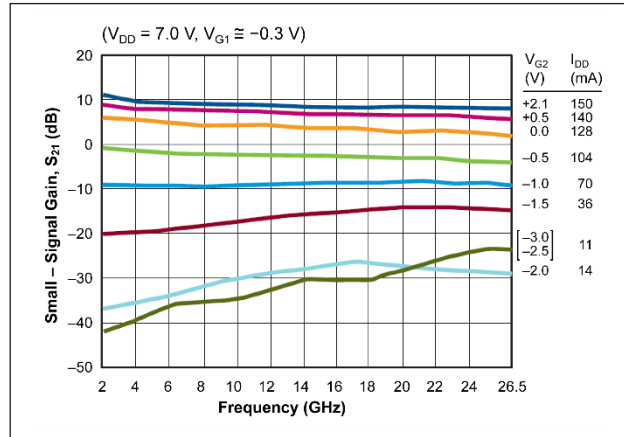

Figure 7. Sample gain vs second gate control voltage.

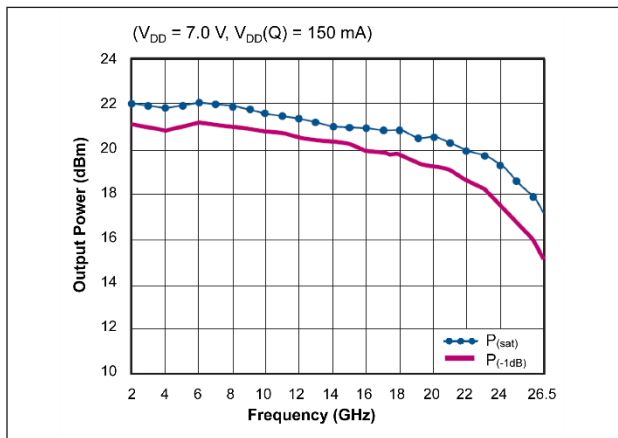

Figure 8. Sample 1dB gain compression and saturated output power.

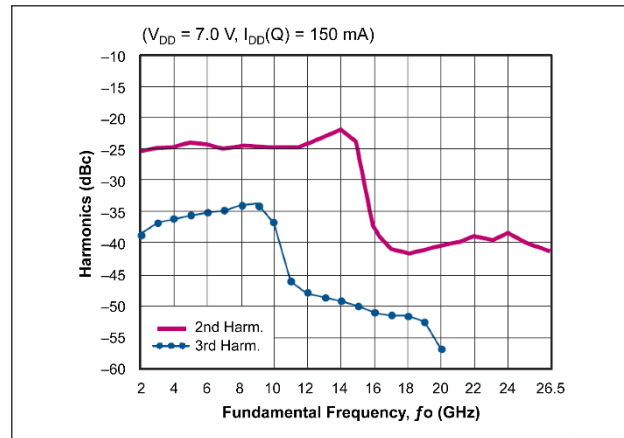

Figure 9. Sample 2nd and 3rd harmonics vs fundamental frequency at $P_{out} = +17\text{ dBm}$.

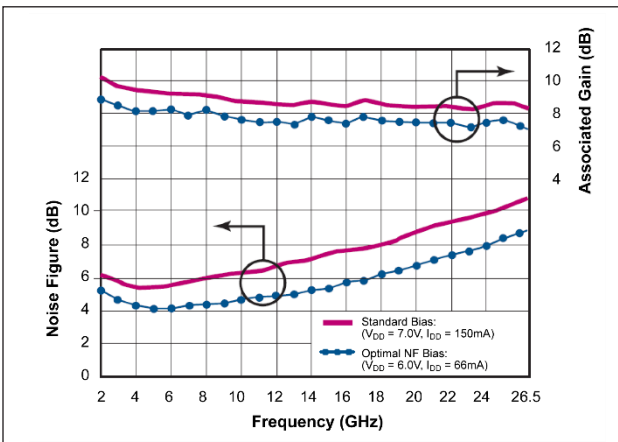

Figure 10. Sample noise figure performance.

Notes

All data measured on individual devices mounted in an Keysight 83040 Series Modular Microcircuit Package @ $T_A = 25^\circ\text{C}$ (except where noted).

This data sheet contains a variety of typical and guaranteed performance data. The information supplied should not be interpreted as a complete list of circuit specifications. Customers considering the use of this, or other TCA GaAs ICs, for their design should obtain the current production specifications from Keysight. In this data sheet the term typical refers to the 50th percentile performance. For additional information and support email mmic_helpline@keysight.com.

Learn more at: www.keysight.com

For more information on Keysight Technologies' products, applications or services, please contact your local Keysight office. The complete list is available at: www.keysight.com/find/contactus

