Keysight M9300A PXIe Frequency Reference 10 MHz and 100 MHz

Notices

Copyright Notices

© Keysight Technologies 2014 - 2016

No part of this manual may be reproduced in any form or by any means (including electronic storage and retrieval or translation into a foreign language) without prior agreement and written consent from Keysight Technologies, Inc. as governed by United States and international copyright laws.

Manual Part Number

M9300-90001

Published By

Keysight Technologies Ground Floor and Second Floor, CP-11 Sector-8, IMT Manesar – 122051 Gurgaon, Haryana, India

Edition

Edition 2, November, 2016

Regulatory Compliance

This product has been designed and tested in accordance with accepted industry standards, and has been supplied in a safe condition. To review the Declaration of Conformity, go to <http://www.keysight.com/go/conformity>

Warranty

THE MATERIAL CONTAINED IN THIS DOCUMENT IS PROVIDED "AS IS," AND IS SUBJECT TO BEING CHANGED, WITHOUT NOTICE, IN FUTURE EDITIONS. FURTHER, TO THE MAXIMUM EXTENT PERMITTED BY APPLICABLE LAW, KEYSIGHT DISCLAIMS ALL WARRANTIES, EITHER EXPRESS OR IMPLIED, WITH REGARD TO THIS MANUAL AND ANY INFORMATION CONTAINED HEREIN, INCLUDING BUT NOT LIMITED TO THE IMPLIED WARRANTIES OF MERCHANTABILITY AND FITNESS FOR A PARTICULAR PURPOSE. KEYSIGHT SHALL NOT BE LIABLE FOR ERRORS OR FOR INCIDENTAL OR CONSEQUENTIAL DAMAGES IN CONNECTION WITH THE

FURNISHING, USE, OR PERFORMANCE OF THIS DOCUMENT OR OF ANY INFORMATION CONTAINED HEREIN. SHOULD KEYSIGHT AND THE USER HAVE A SEPARATE WRITTEN AGREEMENT WITH WARRANTY TERMS COVERING THE MATERIAL IN THIS DOCUMENT THAT CONFLICT WITH THESE TERMS, THE WARRANTY TERMS IN THE SEPARATE AGREEMENT SHALL CONTROL.

KEYSIGHT TECHNOLOGIES DOES NOT WARRANT THIRD-PARTY SYSTEMLEVEL (COMBINATION OF CHASSIS, CONTROLLERS, MODULES, ETC.) PERFORMANCE, SAFETY, OR REGULATORY COMPLIANCE, UNLESS SPECIFICALLY STATED.

Technology Licenses

The hardware and/or software described in this document are furnished under a license and may be used or copied only in accordance with the terms of such license.

U.S. Government Rights

The Software is "commercial computer software," as defined by Federal Acquisition Regulation ("FAR") 2.101. Pursuant to FAR 12.212 and 27.405-3 and Department of Defense FAR Supplement ("DFARS") 227.7202, the U.S. government acquires commercial computer software under the same terms by which the software is customarily provided to the public. Accordingly, Keysight provides the Software to U.S. government customers under its standard commercial license, which is embodied in its End User License Agreement (EULA), a copy of which can be found at <http://www.keysight.com/find/sweula>. The license set forth in the EULA represents the exclusive authority by which the U.S. government may use, modify, distribute, or disclose the Software. The EULA and the license set forth therein, does not require or permit, among other things, that Keysight: (1) Furnish technical information related to commercial computer software or commercial computer software documentation that is not customarily provided to the public; or (2) Relinquish

to, or otherwise provide, the government rights in excess of these rights customarily provided to the public to use, modify, reproduce, release, perform, display, or disclose commercial computer software or commercial computer software documentation. No additional government requirements beyond those set forth in the EULA shall apply, except to the extent that those terms, rights, or licenses are explicitly required from all providers of commercial computer software pursuant to the FAR and the DFARS and are set forth specifically in writing elsewhere in the EULA. Keysight shall be under no obligation to update, revise or otherwise modify the Software. With respect to any technical data as defined by FAR 2.101, pursuant to FAR 12.211 and 27.404.2 and DFARS 227.7102, the U.S. government acquires no greater than Limited Rights as defined in FAR 27.401 or DFAR 227.7103-5 (c), as applicable in any technical data.

Safety Notices

CAUTION

A CAUTION notice denotes a hazard. It calls attention to an operating procedure, practice, or the like that, if not correctly performed or adhered to, could result in damage to the product or loss of important data. Do not proceed beyond a CAUTION notice until the indicated conditions are fully understood and met.

WARNING

A WARNING notice denotes a hazard. It calls attention to an operating procedure, practice, or the like that, if not correctly performed or adhered to, could result in personal injury or death. Do not proceed beyond a WARNING notice until the indicated conditions are fully understood and met.

The following safety precautions should be observed before using this product and any associated instrumentation. This product is intended for use by qualified personnel who recognize

shock hazards and are familiar with the safety precautions required to avoid possible injury. Read and follow all installation, operation, and maintenance information carefully before using the product.

WARNING

If this product is not used as specified, the protection provided by the equipment could be impaired. This product must be used in a normal condition (in which all means for protection are intact) only.

The types of product users are:

- **Responsible body is the individual or group responsible for the use and maintenance of equipment, for ensuring that the equipment is operated within its specifications and operating limits, and for ensuring operators are adequately trained.**
- **Operators use the product for its intended function. They must be trained in electrical safety procedures and proper use of the instrument. They must be protected from electric shock and contact with hazardous live circuits.**
- **Maintenance personnel perform routine procedures on the product to keep it operating properly (for example, setting the line voltage or replacing consumable materials). Maintenance procedures are described in the user documentation. The procedures explicitly state if the operator may perform them. Otherwise, they should be performed only by service personnel.**
- **Service personnel are trained to work on live circuits, perform safe installations, and repair products. Only properly trained service personnel may perform installation and service procedures.**

WARNING

Operator is responsible to maintain safe operating conditions. To ensure safe operating conditions, modules should not be operated beyond the full temperature range specified in the Environmental and physical specification. Exceeding safe operating conditions can result in shorter lifespans, improper module

performance and user safety issues. When the modules are in use and operation within the specified full temperature range is not maintained, module surface temperatures may exceed safe handling conditions which can cause discomfort or burns if touched. In the event of a module exceeding the full temperature range, always allow the module to cool before touching or removing modules from chassis.

Keysight products are designed for use with electrical signals that are rated Measurement Category I and Measurement Category II, as described in the International Electro-technical Commission (IEC) Standard IEC 60664. Most measurement, control, and data I/O signals are Measurement Category I and must not be directly connected to mains voltage or to voltage sources with high transient over-voltages. Measurement Category II connections require protection for high transient over-voltages often associated with local AC mains connections. Assume all measurement, control, and data I/O connections are for connection to Category I sources unless otherwise marked or described in the user documentation.

Exercise extreme caution when a shock hazard is present. Lethal voltage may be present on cable connector jacks or test fixtures. The American National Standards Institute (ANSI) states that a shock hazard exists when voltage levels greater than 30V RMS, 42.4V peak, or 60VDC are present. A good safety practice is to expect that hazardous voltage is present in any unknown circuit before measuring.

Operators of this product must be protected from electric shock at all times. The responsible body must ensure that operators are prevented access and/or insulated from every connection point. In some cases, connections must be exposed to potential human contact. Product operators in these circumstances must be trained to protect themselves from the risk of electric shock. If the circuit is capable of operating at or above 1000V,

no conductive part of the circuit may be exposed.

Do not connect switching cards directly to unlimited power circuits. They are intended to be used with impedance-limited sources. NEVER connect switching cards directly to AC mains. When connecting sources to switching cards, install protective devices to limit fault current and voltage to the card.

Before operating an instrument, ensure that the line cord is connected to a properly grounded power receptacle. Inspect the connecting cables, test leads, and jumpers for possible wear, cracks, or breaks before each use.

When installing equipment where access to the main power cord is restricted, such as rack mounting, a separate main input power disconnect device must be provided in close proximity to the equipment and within easy reach of the operator.

For maximum safety, do not touch the product, test cables, or any other instruments while power is applied to the circuit under test. ALWAYS remove power from the entire test system and discharge any capacitors before: connecting or disconnecting cables or jumpers, installing or removing switching cards, or making internal changes, such as installing or removing jumpers.

Do not touch any object that could provide a current path to the common side of the circuit under test or power line (earth) ground. Always make measurements with dry hands while standing on a dry, insulated surface capable of withstanding the voltage being measured.

The instrument and accessories must be used in accordance with its specifications and operating instructions, or the safety of the equipment may be impaired.

Do not exceed the maximum signal levels of the instruments and accessories, as defined in the specifications and operating information, and as shown on the instrument or test fixture panels, or switching card.

When fuses are used in a product, replace with the same type and rating for continued protection against fire hazard.

Chassis connections must only be used as shield connections for measuring circuits, NOT as safety earth ground connections.

If you are using a test fixture, keep the lid closed while power is applied to the device under test. Safe operation requires the use of a lid interlock.

Instrumentation and accessories shall not be connected to humans.

Before performing any maintenance, disconnect the line cord and all test cables.

To maintain protection from electric shock and fire, replacement components in mains circuits - including the power transformer, test leads, and input jacks - must be purchased from Keysight.

Standard fuses with applicable national safety approvals may be used if the rating and type are the same. Other components that are not safety related may be purchased from other suppliers as long as they are equivalent to the original component (note that selected parts should be purchased only through Keysight to maintain accuracy and functionality of the product). If you are unsure about the applicability of a replacement component, call an Keysight office for information.

WARNING

No operator serviceable parts inside. Refer servicing to qualified personnel. To prevent electrical shock do not remove covers. For continued protection against fire hazard, replace fuse with same type and rating.

PRODUCT MARKINGS:



The CE mark is a registered trademark of the European Community.



Australian Communication and Media Authority mark to indicate regulatory compliance as a registered supplier.

**ICES/NMB-001
ISM GRP.1 CLASS A**

This symbol indicates product compliance with the Canadian Interference-Causing Equipment Standard (ICES-001). It also identifies the product is an Industrial Scientific and Medical Group 1 Class A product (CISPR 11, Clause 4).



South Korean Class A EMC Declaration. This equipment is Class A suitable for professional use and is for use in electromagnetic environments outside of the home.

A 급 기기 (업무용 방송통신기자재)
이 기기는 업무용 (A 급) 전자파적합기
기로서 판 매자 또는 사용자는 이 점을 주
의하시기 바라 며 , 가정외의 지역에서
사용하는 것을 목적으 로 합니다.



This product complies with the WEEE Directive marketing requirement. The affixed product label (above) indicates that you must not discard this electrical/electronic product in domestic household waste. Product Category: With reference to the equipment types in the WEEE directive Annex 1, this product is classified as "Monitoring and Control instrumentation" product. Do not dispose in domestic household waste. To return unwanted products, contact your local Keysight office, or for more information see <http://about.keysight.com/en/companyinfo/environment/takeback.shtml>



This symbol indicates the instrument is sensitive to electrostatic discharge (ESD). ESD can damage the highly sensitive components in your instrument. ESD damage is most likely to occur as the module is being installed or when cables are connected or disconnected. Protect the circuits from ESD damage by wearing a grounding strap that provides a high resistance path to ground. Alternatively, ground yourself to discharge any buildup static charge by touching the outer shell of any grounded instrument chassis before touching the port connectors.



This symbol on an instrument means caution, risk of danger. You should refer to the operating instructions located in the user documentation in all cases where the symbol is marked on the instrument.



This symbol indicates the time period during which no hazardous or toxic substance elements are expected to leak or deteriorate during normal use. Forty years is the expected useful life of the product.

Contents

Documentation Access	7
M9300A Introduction	8
M9300A Introduction	8
Follow the Startup Sequence	8
Related Documentation	8
Step 1 - Unpack and Inspect the Module	11
Step 1: Unpack and Inspect the Module	11
ESD	11
Inspect for Damage	11
Return a Module for Service	12
Step 2: Verify M9300A Shipment Contents	13
Step 3 - Install the Software	14
Step 3: Install the Software	14
System Requirements	14
Hardware Requirements	14
Chassis Requirements	15
Power up the Controller	16
Software Installation Overview	16
Software Installation Procedure	16
Step 4 - Install the Module	19
Step 4: Install the Module	19
Module Installation Process Overview	19
M9300A Modular Instrument Connections	21
M9300A Modular Instrument Connections	21
Sharing the M9300A Frequency Reference	21
Cable and Connector Care	24
M9300A PXIe Frequency Reference Front Panel Features	25
Block Diagram	26
M9300A Block Diagram	26
M9300A Block Diagram Reference Table for M9300A	26
Step 5: Verify Operation of the M9300A Module (Optional)	28
Step 6: Installation is Complete	29
API Overview	29
LabVIEW Driver	29
M9300A Specifications	30
M9300A Module Troubleshooting	31
M9300A PXIe Frequency Reference Module Troubleshooting	31
Module-Level Troubleshooting Overview	31
Keysight M9300A PXIe Frequency Reference Troubleshooting	31
M9300A Status LEDs	34

Documentation Access

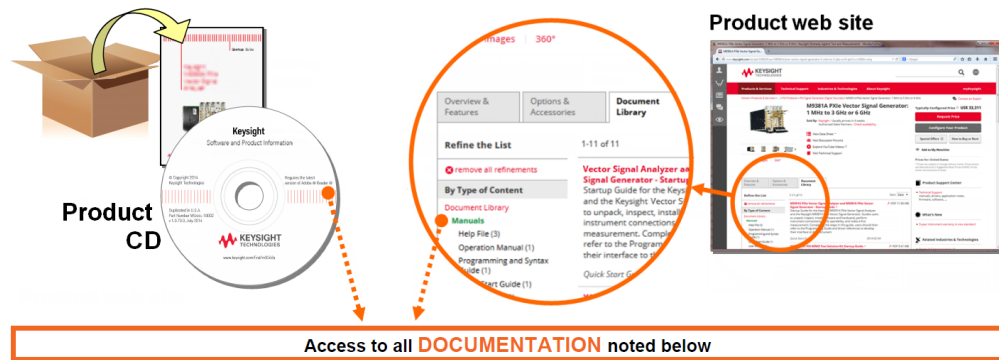

Startup Guide



- Unpack product
- Verify shipment
- Install software
- Install hardware
- Verify operation
- Troubleshooting

Data Sheet



- Product description
- Technical specifications

Programming Guide



- Product intro
- Programming Procedures
- Sample Programs

Soft Front Panel (SFP) user interface

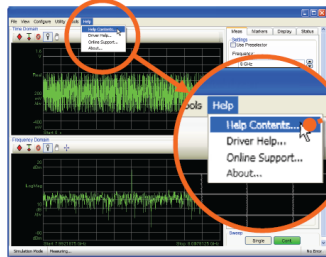

SFP help system

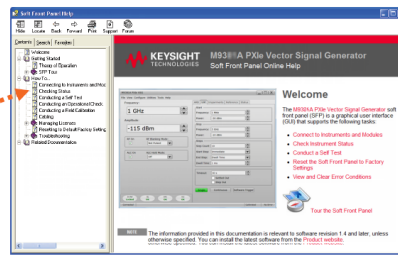

- Theory of operation
- Block diagram
- Configuration
- Self test
- Operational check
- Field calibration
- Troubleshooting

Visual Studio

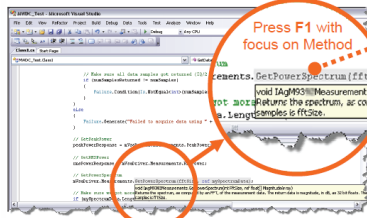

Press F1 with focus on Method

IVI Driver help system



- IVI-COM and IVI-C driver reference
- Sample programs

LabVIEW

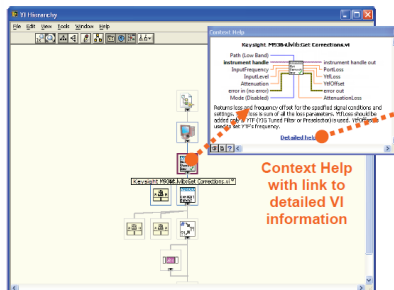

Context Help with link to detailed VI information

LabVIEW Driver help system

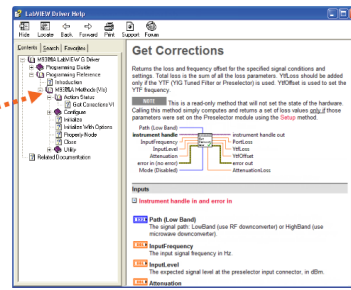

- LabVIEW driver reference
- Sample programs

M9300A Introduction

M9300A Introduction

The scope of this Startup Guide is to detail the processes of receiving and installing the Keysight M9300A PXIe Frequency Reference, installing the required software, and verifying basic module operation. If you have any questions after reviewing this information, please contact your local Keysight Technologies Inc. representative or contact us through our website at www.keysight.com/find/M9300A.

NOTE

Keysight Technologies is changing the color of the front panel of its products. During the transition to new colors, you might receive modules that do not match the pictures in the documentation. These products work the same as they did before the color change and no action is required.

Follow the Startup Sequence

WARNING

Closely follow the startup process flow in this document. Deviating from the sequence can cause unpredictable system behavior, damage your system, and may cause personal injury.

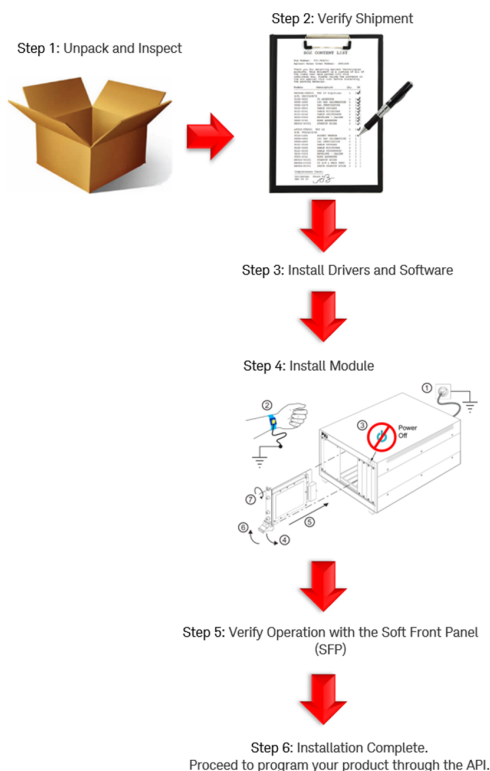

Related Documentation

To access documentation related to the Keysight M9300A PXIe Frequency Reference, use one of the following methods:

- If the product software is installed on your PC, the related documents are also available in the software installation directory.

Document	Description	Default Location on 64-bit Windows system	Format
Soft Front Panel (SFP) help system	Provides product introduction, tour of the SFP user interface, how-to procedures (for example, configuration, self test, operational check), and troubleshooting.	C:\Program Files (x86)\Agilent\M938x\Help\M9300_SFP_Help.chm	CHM (Microsoft Help Format)
Data Sheet	In addition to a detailed product introduction, the data sheet supplies full product specifications.	C:\Program Files (x86)\Agilent\M938x\Help\M9300_DataSheet_5991-0898EN.pdf	PDF
IVI Driver reference (help system)	Provides detailed documentation of the IVI-COM and IVI-C driver API functions, as well as information to help you get started with using the IVI drivers in your application development environment.	C:\Program Files (x86)\Agilent\M938x\Help\AgM9300.chm	CHM (Microsoft Help Format)
LabVIEW Driver Reference	Provides detailed documentation of the LabVIEW G driver API functions.	C:\Program Files (x86)\Agilent\M938x\Help\AgM9300_LabVIEW_Help.chm	CHM (Microsoft Help Format)

NOTE

Alternatively, you can find these documents under: **Start > All Programs > Keysight > M938x.**

- The documentation listed above is also available on the product CD.
- To understand the available user documentation in context to your workflow, go to [Documentation Access](#).
- To find the very latest versions of the user documentation, go to the product web site (www.keysight.com/find/M9300A) and download the files from the Manuals support page (go to Document Library > Manuals):

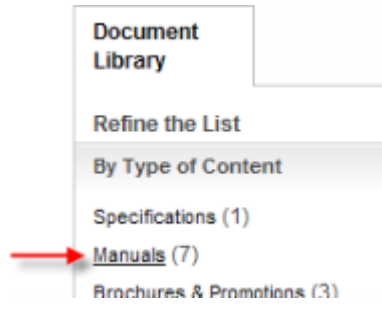

Step 1 - Unpack and Inspect the Module

Step 1: Unpack and Inspect the Module

CAUTION

The module is shipped in materials which prevent damage from static. The module should only be removed from the packaging in an anti-static area ensuring that correct anti-static precautions are taken. Store all modules in anti-static envelopes when not in use.

ESD

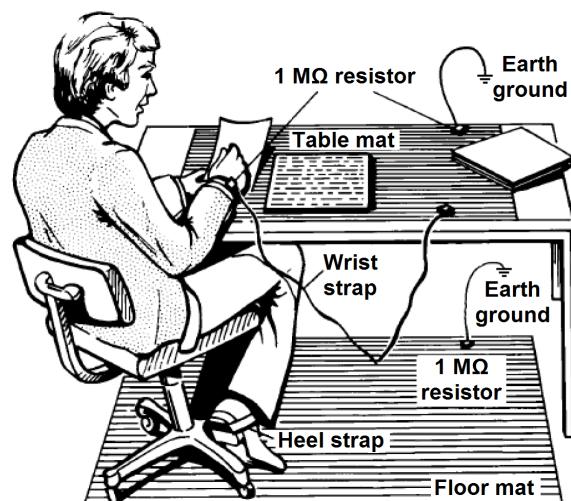

Electrostatic discharge (ESD) can damage or destroy electronic components. Use a static-safe work station to perform all work on electronic assemblies. The figure (left) shows a static-safe work station using two types of ESD protection: conductive table-mat and wrist-strap combination, and conductive floor-mat and heel-strap combination. Both types, when used together, provide a significant level of ESD protection. Of the two, only the table-mat and wrist-strap combination provides adequate ESD protection when used alone. To ensure user safety, the static-safe accessories must provide at least 1 MΩ of isolation from ground.

WARNING

DO NOT use these techniques for a static-safe work station when working on circuitry with a voltage potential greater than 500 volts.

Inspect for Damage

After unpacking a module, inspect it for any shipping damage. Report any damage to the shipping agent immediately, as such damage is not covered by the warranty (see warranty information at beginning of this document).

CAUTION

To avoid damage when handling a module, do not touch exposed connector pins.

Return a Module for Service

Should it become necessary to return a module for repair or service, follow the steps below:

1. Review the warranty information shipped with your product.
2. Contact Keysight to obtain a Return Material Authorization (RMA) and return address. For assistance finding Keysight contact information, go to www.keysight.com/find/assist.
3. Write the following information on a tag and attach it to the malfunctioning equipment:
 - Name and address of owner. A P.O. box is not acceptable as a return address.
 - Module serial number(s). The serial number label is located on the side panel of the module. The serial number can also be read from the Soft Front Panel interface - *after* the hardware is installed.
 - Description of failure or service required.
4. Pack the module in its original ESD bag and packing carton. If the original carton is not available, use bubble wrap or packing peanuts and place the instrument in a sealed container and mark the container "FRAGILE".
5. On the shipping label, write ATTENTION REPAIR DEPARTMENT and the RMA number.

NOTE

In your correspondence, refer to the modules by serial number and the instrument by model number.

Step 2: Verify M9300A Shipment Contents

The following items are included with your Keysight M9300A PXIe Frequency Reference order:

- Keysight PXI Vector Signal Generator Software and Product Information CD. It contains software, drivers and all product printed documentation in PDF format. The part number for this CD is M9300-10002.
- Keysight IO Libraries Suite CD. The part number for this CD is E2094-60003.
- Keysight M9300A PXIe Frequency Reference Startup Guide in hard copy (M9300-90001)
- Cable, coaxial, A01/A07 50 ohm, male BNC to female SMB, 1200 mm length (8121-2063)

NOTE

All the files contained on the CDs are available for download at www.keysight.com/find/M9300A.

Step 3 - Install the Software

Step 3: Install the Software

System Requirements

Topic	Windows 7 Requirements
Operating system	Windows 7 (32 bit and 64 bit), WES7
Processor speed	1 GHz 32-bit (x86), 1 GHz 64-bit (x64), no support for Itanium64
Available memory	4 GB minimum (8 GB recommended for 64-bit operating systems)
Available disk space ¹	1.5 GB available hard disk space, includes: <ul style="list-style-type: none">- 1 GB available for Microsoft .NET Framework 3.5 SP1²- 100 MB for Keysight IO Libraries Suite
Video	Support for DirectX 9 graphics with 128 MB graphics memory recommended (Super VGA graphics is supported)
Browser	Microsoft Internet Explorer 7.0 or greater

1 This is the required disk space for installation. Typically, less disk space is required for operation than is required for installation.

2 .NET Framework Runtime Components are installed by default with Windows 7 and Vista. Therefore, you may not need this amount of disk space.

Hardware Requirements

Topic	Requirements
Chassis	PXle or PXI-H chassis slot
Controllers	A PXI or PXI Express embedded controller or remote controller (external PC connected to the chassis by a PCI-to-PXI interface) is required.

Topic	Requirements
Embedded controller	<p>Keysight M9036A or M9307A or an embedded controller that meets the following requirements:</p> <ul style="list-style-type: none"> - PXIe system controller (PXI-1 embedded controllers are not compatible) - Utilize a 2x8, or 4x4 PXIe system slot link configuration. - Run one of the operating systems listed in System Requirements (above).
Remote controller	<p>(for Keysight M9018A chassis use only) A PC running one of the operating systems listed in System Requirements above and a Keysight M9021A Cable Interface x8 with one of the following PC interface options:</p> <ul style="list-style-type: none"> - Keysight M9045B PCIe ExpressCard Adaptor x1, with cable (for a laptop PC) - Keysight M9048A PCIe Desktop Adaptor x8, with cable (for desktop PCs)

Chassis Requirements

Recommended best practices to ensure proper and safe module operating conditions:

- Ensure proper chassis air flow is maintained
- Select a chassis that provides thermal protection if fans become inoperable or forced air cooling is obstructed
- Use slot blockers (Keysight model Y1212A, 5 per kit) and EMC filler panels in empty module slots to ensure proper operating temperatures. Keysight chassis Keysight M9018A chassis and slot blockers optimize module temperature performance and reliability of test.
- Set chassis fans to high or auto. Do not disable fans.
- Position chassis to allow plenty of space around chassis air intake and fan exhaust.
- At environment temperatures above 45 °C, set chassis fan speed to high.

M9018A Chassis Air Flow



The M9018A has multiple air intakes. They are located at the lower sides, lower front, and bottom of the chassis.

Power up the Controller

CAUTION If you are using a remote controller and you have installed the interface cable, you must power up the chassis **BEFORE** you power up the PC. When you power down your chassis, Shut Down the PC **BEFORE** you power down the chassis.

If you are using an embedded controller, complete the following steps:

1. Install the embedded controller module into the compatible chassis. The Keysight M9036A PXIe Embedded Controller and Keysight M9018A PXIe Chassis are recommended. Please refer to the embedded controller and chassis documentation for further details.
2. Connect peripherals (mouse, keyboard, monitor).
3. Power up the chassis.

Software Installation Overview

This installation includes the following:

- Keysight IO Libraries Suite (IOLS), which includes the Keysight Connection Expert. This software is included with your shipment, and is also available at www.keysight.com/find/iosuite. This software must be installed first.

NOTE Version 16.1.4931.0 (or newer) of the Keysight IO Libraries Suite is required.

- Instrument software, which includes the soft front panel (SFP), device drivers (IVI-C, IVI-COM, and LabVIEW G) and documentation for the M9380A PXIe CW Source and M9391A PXIe Vector Signal Analyzer. This software is included with your shipment and is also available at www.keysight.com/find/M9300A.

Software Installation Procedure

1. Install the Keysight IO Libraries Suite. Follow the installer prompts to install the IO libraries.
2. Install the M9300A product software:

a. Launch the Keysight PXIe VSA installer.

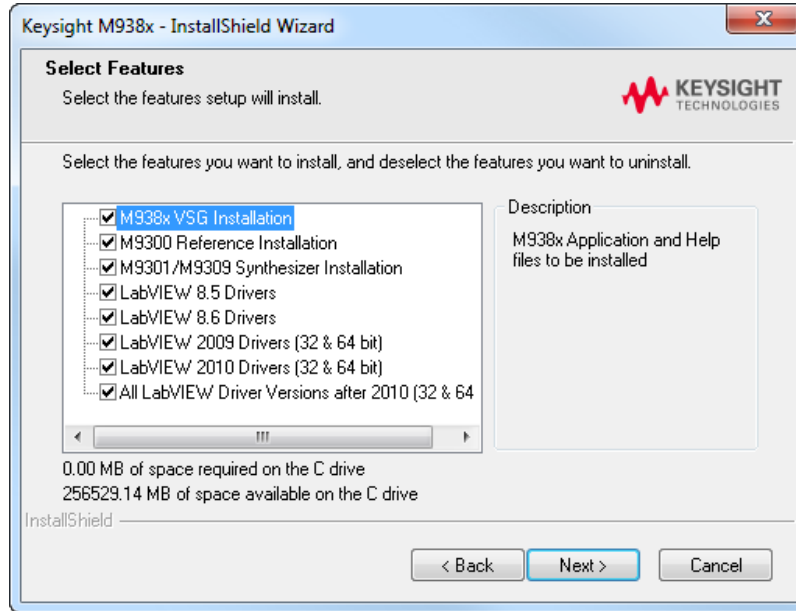

b. Follow the installer prompts. Choose a "Complete" installation to install all software and documentation, or a "Custom" installation to select from a listing of modules and other features.

NOTE If you intend to install only the M9300A software, select "Custom" in the Setup Type prompt. In the Select Features prompt, deselect "M938x VSG Installation".

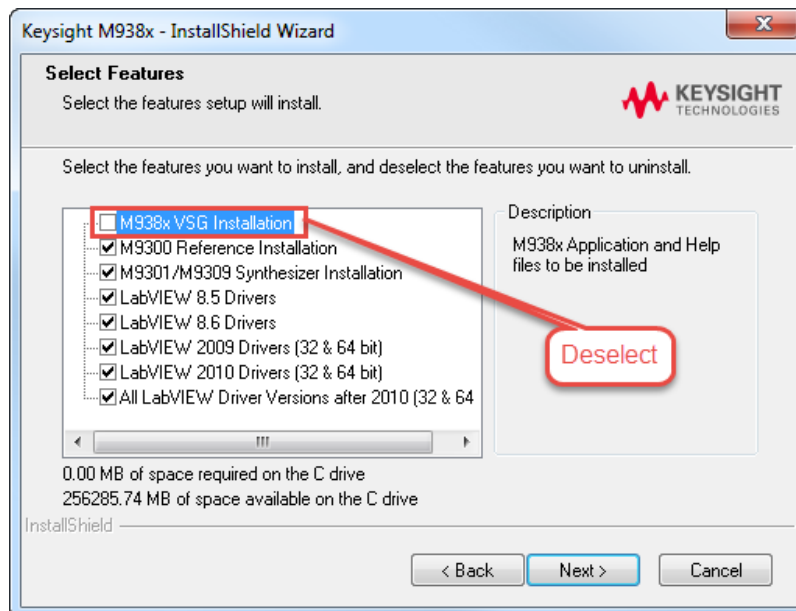

c. Complete the installation.

Embedded controller M9036A, M9037A):

- i. Select "Yes, I want to restart my computer now." This is the default selection.

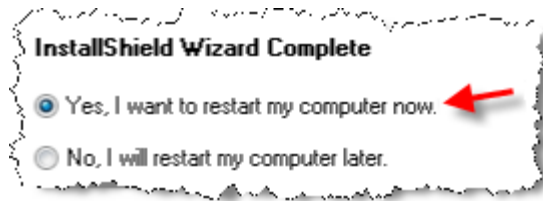

- ii. Click on Finish.
- iii. Wait for the system to restart.

Remote controller:

(Follow these steps in order, or else instrument damage may result.)

- i. Select "No, I will restart my computer later."



- ii. Click on Finish.
- iii. Shut down the remote controller PC. Use Start > Shut down.
- iv. Power down the chassis.
- v. Power up the chassis.
- vi. Power up the remote controller PC.

Step 4 - Install the Module

Step 4: Install the Module

CAUTION

PXI hardware does not support "hot-swap" (changing modules while power is applied to the chassis) capabilities. Before installing or removing a module to/from the chassis, power off the chassis to prevent damage to the module.

NOTE

This module can be used in a chassis with PXIe or PXI-H chassis slots.

Module Installation Process Overview

7^H The module can be installed in any PXIe or hybrid PXI slot marked with a peripheral slot compatibility image (solid black circle for PXIe, or solid black circle with the letter -H- for hybrid).

7

1. Make sure that the line cord is plugged in to establish earth ground and that the chassis power switch is Off.
2. If the chassis has multiple fan speed settings, ensure that the fan switch is set to AUTO and the inhibit switch is set to DEF.

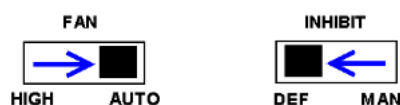

3. Position the chassis to provide ample space between the chassis fan intake and exhaust vents. Blockage by walls or obstructions affects the air flow needed for cooling. (Refer to the chassis documentation for more information about cooling).
4. Before inserting a module into the chassis, back the mounting screws out to ensure that there is no interference between the screws and the mounting rails.
5. See [M9300A Modular Instrument Connections](#) for positioning the M9300A module as a component of the Keysight M9380A PXIe CW Source or the Keysight M9381A PXIe Vector Signal Generator. Install the left-most module first and then proceed installing modules from left to right. If only the M9300A is to be installed, any PXIe or PXI-H slot may be used.

6. Holding the module by the injector/ejector handle, slide it into an available PXI (or hybrid) slot, as shown in the following figure.
 - a. Install the module into the slot of the chassis by placing the module card edges into the front module guides (top and bottom).
 - b. Slide the module to the rear of the chassis and ensure that the injector/ejector handle is pushed down in the unlatched (downward) position.
 - c. Slide the module completely into the chassis. When you begin to feel resistance, pull up on the injector/ejector handle to fully inject the module into the chassis.

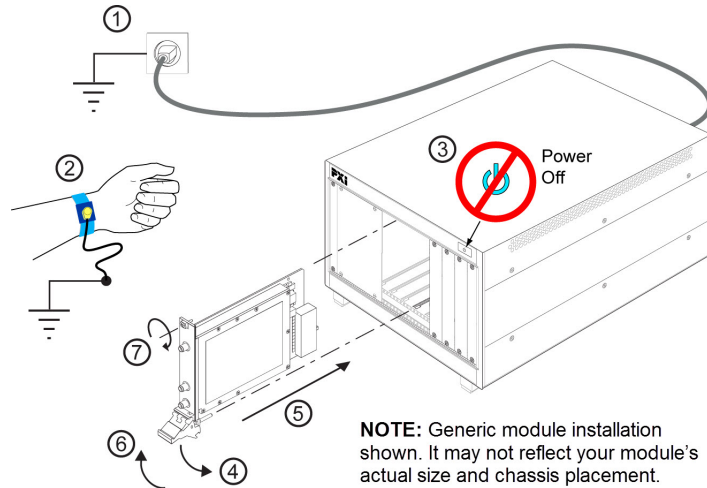

7. Secure all modules to the chassis using the module mounting screws. Use a #1 Pozidriv® or a slotted screwdriver and torque to 5 Lb-In (0.57 N-m). Performance may suffer if the screws are not tightened properly.
8. Verify that the PXI chassis fans are operable and free of dust and other contaminants that may restrict airflow.
9. Install filler panels and slot blockers after installing the modules. Missing filler panels or slot blockers may disrupt air circulation in the chassis. The left-most slot does not accept a slot blocker.
10. Use the Cabling Diagram on the next page to attach the cables to the instrument. The torque specification for SMA connectors is 8 Lb-In (0.904 Nm).
11. Power up the PXI chassis.
12. If you are using a remote PC, reboot the PC host.
13. Proceed to **Step 5 - Verify Operation of the M9300A Module (Optional)**.

M9300A Modular Instrument Connections

M9300A Modular Instrument Connections

This section contains a cabling diagram for the Keysight M9380A PXIe CW Source and for the Keysight M9381A PXIe Vector Signal Generator. It also includes a table of front panel features for the M9300A module.

Keysight M9380A PXIe CW Source

Keysight M9381A PXIe Vector Signal Generator

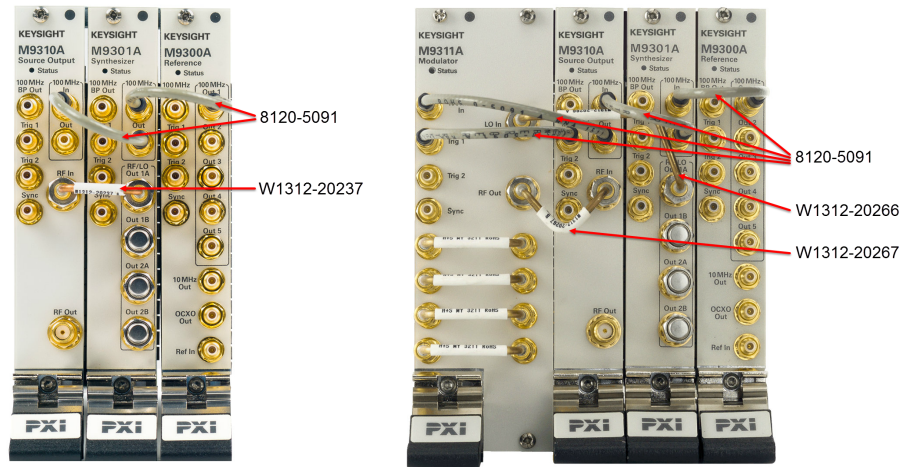

CAUTION

Before removing cables from SMB and MMCX connectors, **Cable and Connector Care**.

For detailed information on the Keysight M9380A/M9381A sources (cabling, performance verification and SFP use), see www.keysight.com/find/M9381A.

For front panel feature descriptions of the M9300A, see [M9300A PXIe Frequency Reference Front Panel Features](#).

Sharing the M9300A Frequency Reference

Sharing the M9300A Frequency Reference

The M9300A Frequency Reference module can be shared by multiple instruments, such as all the M9381A Vector Signal Generators and M9391A Vector Signal Analyzers in your chassis. You can also synchronize multiple chassis to ensure that the instruments initialize with aligned clocks—see [Synchronizing Multiple Chassis](#).

If you connect to a hardware configuration that includes a currently connected M9300A (either independently or as part of another hardware configuration) the latest instance of the SFP will take control of the M9300A. You will see no warning or error message.

CAUTION

While the M9300A module is being shared, any of the configurations that share this reference can control it fully, including setting the reference to use an external frequency reference source. If the external frequency reference setting does not match that of the supplied frequency, the reference will be unlocked, as expected. However, only the instance of the SFP that creates the reference unlock condition can correct the problem. This is done by either correcting the frequency or by setting the reference back to internal, so that a subsequent instance will not take control of the reference module unintentionally.

NOTE

If you set the frequency for the external reference in one configuration, that value is not reflected in the other configurations sharing the reference. For example, if you set the external reference frequency to 8 MHz in the M9381A SFP, the M9391A SFP will still show the default value of 10 MHz.

CAUTION

The Reference module can also be shared among multiple measurement applications, such as the Keysight 89600 VSA software. The Reference module must be initialized before use, so including it in all configurations allows applications to be started in any order. However, when sharing a module the user interface of some applications may not reflect M9300A settings made by other applications. For example, the Keysight 89600 software can control the Reference module internal/external setting, but the changes made by other applications will not be reflected in the Keysight 89600.

NOTE

FPGA updates are not allowed on a Keysight M9300A PXIe Frequency Reference while it is being shared. To perform M9300A FPGA updates, reserve the Reference.

Reserving the Reference for a Configuration

If you are running a test in the background with a certain M9300A setting and then connect a hardware configuration that also contains the same M9300A, you may alter the test setup that is already running.

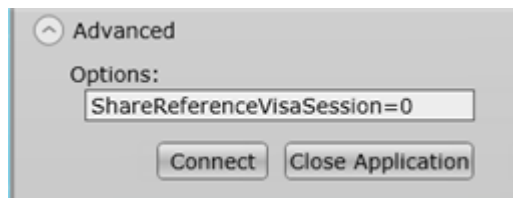

If you would prefer to be keep the reference control with the first instance of the hardware configuration so that a subsequent instance will not take control of the reference module unintentionally:

1. On the SFP Connect to Instrument screen, click the Advanced control to open the Options: dialog.

2. Type the following string: `ShareReferenceVisaSession=0`

This configuration will retain control of the M9300A if you try to open a new configuration. If you connect a new configuration, that includes the same M9300A, you will see the following error:

CAUTION If an existing instance of the SFP is connected to the reference module in a shared (default) mode, and you try to connect a second instance of the SFP to the same reference with `ShareReferenceVisaSession=0` Advanced Option, you will get the resource locked error shown above.

Synchronizing Multiple Chassis

When synchronizing multiple chassis, you must provide the same 10 MHz frequency reference to the M9300A located in slot 10 of each chassis. You can either use the 10 MHz *OCXO Out* from the Keysight M9300A PXIe Frequency Reference master or an external 10 MHz frequency reference. The timing of the 10 MHz frequency reference is critical, so a symmetric splitter and equal length cables should be used to split the 10 MHz and connect to the M9300A *Ref In* connector in each chassis. Each M9300A must be in external reference mode (Use External Reference) and the OCXO Out (if used) must be enabled. The M9300A frequency locks an internal 100 MHz oscillator to the 10 MHz frequency reference and divides the 100 MHz signal to create a local 10 MHz, which is then routed to modules in the chassis using the PXIe backplane. This local 10 MHz signal does not have a guaranteed phase relationship to the 10 MHz frequency reference. Therefore, before the instruments in the chassis are initialized, select **Utilities > Align 10MHz Phase** to align the 10 MHz Out with the 10 MHz frequency reference. This ensures that the instruments initialize with aligned clocks. The alignment needs to be repeated whenever the 10 MHz cabling is changed, whenever power is cycled, and once every 24 hours to ensure the clocks don't drift.

NOTE The M9300A SFP and IVI provide a method to shift the timing of the 100 MHz oscillator (**Utilities > Time Shift**). Changing the time shift will invalidate the multiple chassis synchronization from **Align 10 MHz Phase**.

Example Two Chassis Receiver Configuration, two receivers per Chassis

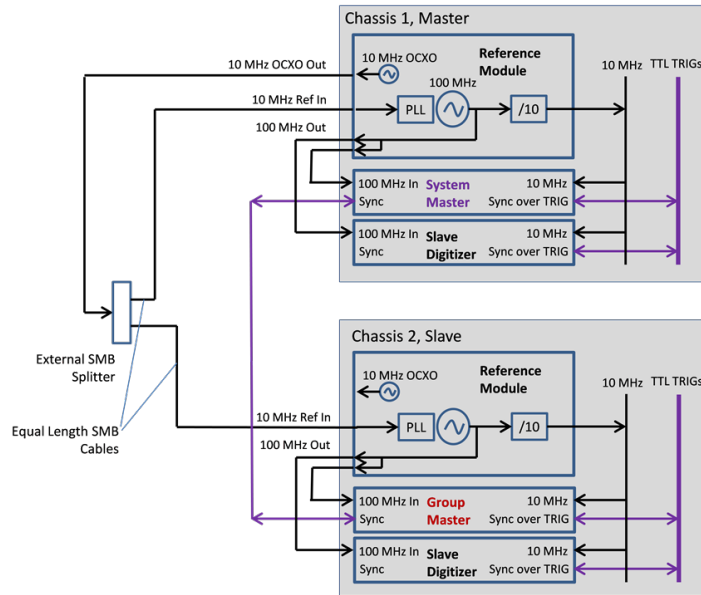

Cable and Connector Care

Use the Keysight Cable Removal Tool to disconnect push-on cables from the module front panel connectors.

CAUTION To avoid damage to the cables or connectors, pull the cable straight away from the connector. Do not use the tool as a pry bar.

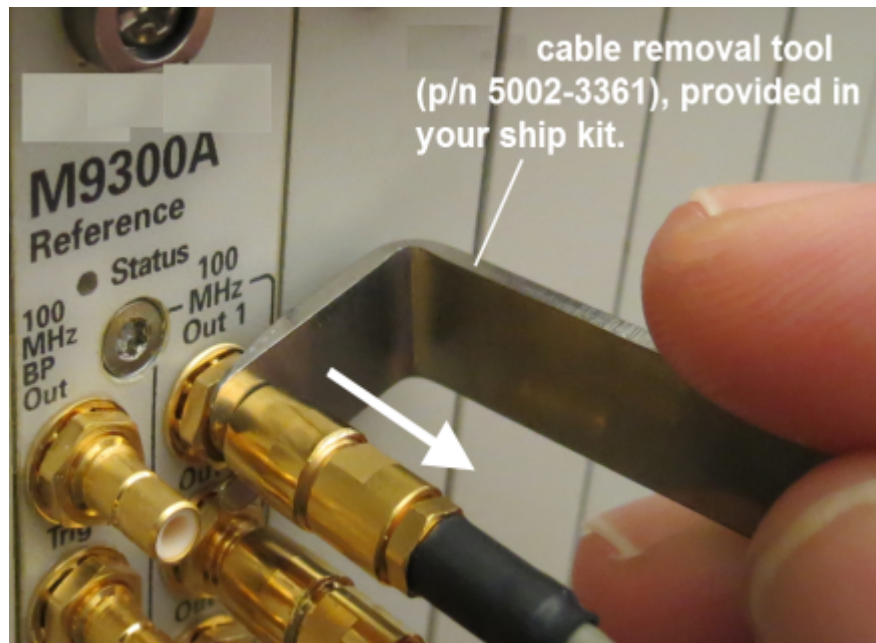

M9300A PXle Frequency Reference Front Panel Features

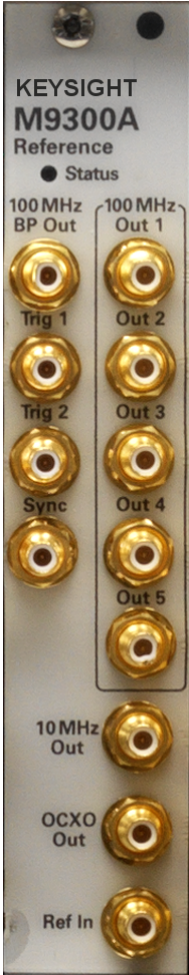
Connector	Description
	<p>100 MHz BP Out This SMB male connector outputs a 100 MHz signal from the chassis backplane board. This output is enabled through the SFP.</p>
<p>100 MHz Out 1 through Out 5</p>	<p>Each of these SMB male connectors may output a 100 MHz reference and clock signal to the 100 MHz In connector of the Keysight M9301A PXle Synthesizer.</p>
Trig 1	This connector is intended for future use.
Trig 2	This connector provides a programmable output trigger.
Sync	This connector is intended for future use.
10 MHz Out	This SMB male connector provides a 10 MHz signal. This output is enabled through the SFP.
OCXO Out	This SMB male connector provides a 10 MHz signal from the 10 MHz OCXO timebase. This output is enabled through the SFP.
Ref In	This SMB male connector inputs a 1 MHz to 110 MHz reference signal. The connector is AC coupled and terminated into 50 Ω .

Block Diagram

M9300A Block Diagram

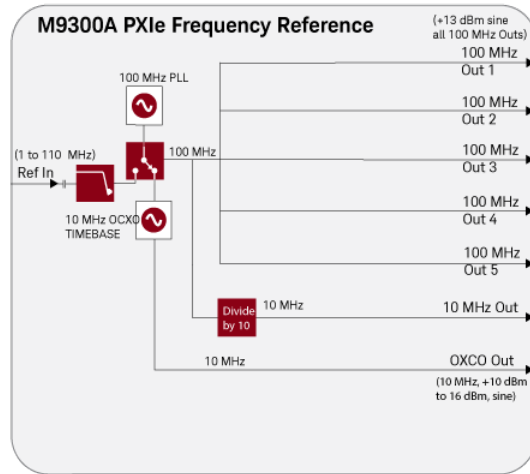

M9300A Block Diagram Reference Table for M9300A

M9300A PXIe Reference Operation		
Input	Connector	Output
From: External Reference Frequency: 1 MHz to 110 MHz Input Level: -5 dBm to +20 dBm	Ref In	
	100 MHz Out 1-5	Frequency: 100 MHz Output level: >+12 dBm sine (+13 dBm typical)
	10 MHz Out	Output level: 3.3 Vpp square (1.65 v into 50 Ω)
	OCXO Out	Frequency: 10 MHz, AC coupled , 50 Ω source.

M9300A PXIe Reference Operation

Input	Connector	Output
		Output level: +10 dBm to +16 dBm, from 10 MHz OCXO.
	Sync	This connector is intended for future use.
Sine or square wave -2 V to +5 V max into 50 Ω , +16 dBm max @ 0 VDC into 50 Ω	Trigger 1 & 2 (In/Out)	3.3 V into 50 Ω
From : Chassis back plane board Frequency: 100 MHz	100 MHz BP Out	Frequency: 100 MHz Output level: +10 dBm

Step 5: Verify Operation of the M9300A Module (Optional)

In this step you will verify correct operation of the Keysight M9300A PXIe Frequency Reference. Before running a Self Test or performing a Calibration, assure that all required software is installed, the chassis is powered on, and all cabling is correct. See [M9300A Modular Instrument Connections](#) for proper cabling.

The first step in this process is to conduct a Self Test of the M9300A.

1. Open the M9300A soft front panel (SFP) by selecting Start > All Programs > Keysight > M938x > M9300 SFP.
2. Upon opening the SFP, you are presented with the "Connect to Instrument" dialog. Select the M9300 A module that is installed in the chassis and press Connect. For example:

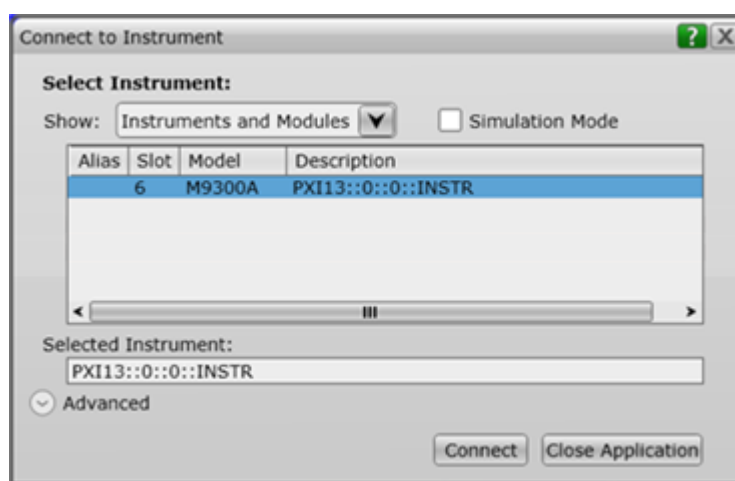

NOTE

If no modules are visible in the SFP "Connect to Instrument" dialog, see [M9300A PXIe Frequency Reference Module Troubleshooting](#).

3. Conduct a Self Test (Utilities > Self Test... > Run Self Test). The M9300A Self Test runs the module through its Self Test.

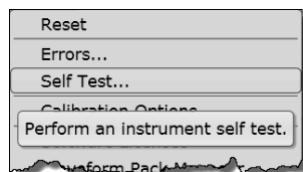

If the Self Test passes, go to [Step 6: Installation is Complete](#).

CAUTION

If the M9300A Self Test fails, see [M9300A PXIe Frequency Reference Module Troubleshooting](#) to clearly determine the source of the failure.

Step 6: Installation is Complete

Proceed to program your product by means of the applications programming interface (API) for the supplied drivers.

API Overview

Keysight's IVI drivers simplify the creation and maintenance of instrument control applications in a variety of development environments; they allow programmatic control of instrumentation while providing a greater degree of instrument interchangeability and code reuse. IVI drivers currently come in two basic types: IVI-COM and IVI-C. Although the functionality offered by both types of drivers is often very similar, the fundamental differences in interface technology results in a very different end-user experience. The IVI drivers support compiling application programs for 32- or 64-bit platforms.

Supported ADEs (application development environments) Arguably the most important consideration in comparing IVI-COM and IVI-C drivers is the end user experience in various ADEs. Since IVI-COM drivers are based on Microsoft COM technology, it's not surprising that IVI-COM drivers offer the richest user experience in Microsoft ADEs. Users working in Visual C++, Visual C#, Visual Basic.NET, and Visual Basic 6 enjoy a host of features, such as object browsers, IntelliSense, and context-sensitive help.

When you install the product software, the IVI driver files are installed in the standard IVI Foundation directories (for example, C:\Program Files\IVI Foundation\IVI\Drivers\AgM9300). Example programs are provided to demonstrate most driver functionality (for example, C:\Program Files\IVI Foundation\IVI\Drivers\AgM9300\Examples). The reference material for the driver functions (a Microsoft HTML Help .chm file) is installed with the IVI driver and is available for Microsoft Visual Studio's IntelliSense context linking. In addition, you can directly access the .chm file (AgM9300.chm) from this Start menu location: Start > All Programs > Keysight IVI Drivers > AgM9300 Reference > Documentation.

LabVIEW Driver

In addition to the IVI drivers, Keysight provides a LabVIEW driver that includes all the functionality of the IVI-C driver. When you install the product software, the LabVIEW driver is installed to each LabVIEW instr.lib directory for each version of LabVIEW you have on your computer (for example, C:\Program Files (x86)\National Instruments\<LabVIEW version>\instr.lib\<Keysight product model>). If you install LabVIEW drivers before you install LabVIEW itself, drivers will be installed in the Keysight directory instead of the National Instruments directory (for example, C:\Program Files (x86)\Keysight\<Keysight product model>\LabVIEW Driver\<LabVIEW version>\...). Example programs are provided to demonstrate most driver functionality. The reference information for the driver (a Microsoft HTML Help .chm file) is also installed with the driver and the content is available from LabVIEW's Context Help window. In addition, you can directly access the chm file (AgM9300_LabVIEW_Help.chm) from this Start menu location: Start > All Programs > Keysight > M938x > M9300 LabVIEW Help.

M9300A Specifications

The specifications for the M9300A are contained in the Keysight M9300A Data Sheet. The Data Sheet for the M9300A is included on the Keysight M9300A PXIe Source and Analyzer Series Software and Product Information CD that came with your module. Please check the Keysight website at www.keysight.com/find/M9300A for the latest updates to this information. The Data Sheet for the M9300A can also be found at <http://literature.cdn.keysight.com/litweb/pdf/5991-0898EN.pdf>.

M9300A Module Troubleshooting

M9300A PXIe Frequency Reference Module Troubleshooting

Module-Level Troubleshooting Overview

To troubleshoot a module-level problem with the M9300A, first:

1. Check cabling.
2. Check the front panel Status LEDs. See [M9300A Status LEDs](#) .
3. Check the M9300A SFP Instrument Self Test.
4. Perform a module-level troubleshooting check.

Keysight M9300A PXIe Frequency Reference Troubleshooting

Start the soft front panel (SFP) self test by selecting Utilities > Self Test > Run Self Test. Once completed, a dialog box appears and reports on the module. Indicating whether it passed or failed the Self Test.

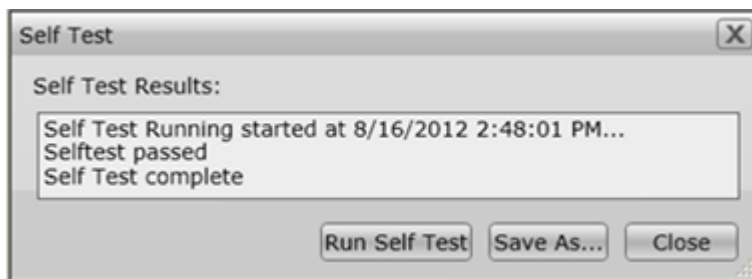

Recommended Hardware

Please refer to the following table for recommended hardware. Additionally, a high quality flexible 3.5 mm cable is required, plus adapters to connect the PSG (precision signal generator) and signal analyzer.

Hardware	Description	Critical parameters
Keysight N9020A Option 508 or N9030A Option 508 or E44454A	Signal Analyzer	1 MHz to 6 GHz
Keysight N5181A	Source or Function Generator	1 MHz to 110 MHz, ± 5 dBm

Ref In Connector

1. On the M9300A SFP, under External Reference, enable Use External Reference.

NOTE

The External Reference status indicator will show an "Unlocked" condition and the Status LED on the front panel will turn red until an external reference is applied.

2. Connect an external source or function generator output to the M9300A "Ref In" connector.
3. Set the source/function generator to the first frequency and power level listed in the following table.
4. On the SFP (under External Reference) enter the external reference frequency in "Frequency".
5. Verify that the Reference is locked, using the SFP Reference Status indicators.
6. Set the source/function generator to each frequency and power level listed in the following table, and verify that the reference locks.

SFP External Reference Frequency	Source Frequency	Source Power Level (sine)
1 MHz	1 MHz	+10 dBm
1 MHz	1 MHz	0 dBm
10 MHz	10 MHz	+10 dBm
10 MHz	10 MHz	0 dBm
100 MHz	100 MHz	+10 dBm
100 MHz	100 MHz	0 dBm
110 MHz	110 MHz	+10 dBm
110 MHz	110 MHz	0 dBm

NOTE

Cable loss must be considered, when determining the results.

7. If the Reference remains locked at all frequencies and power levels, proceed to next test.
8. If the Reference module fails to lock, it is defective and needs repair. See [Return a Module for Service](#) .
9. Uncheck, "Use External Reference" and remove the cable from the Ref In connector.

10. If the Reference loses lock, the module is defective and should be repaired. See [Return a Module for Service](#) .

NOTE

Use the following procedure to check the M9300A Reference Module, using a spectrum analyzer.

100 MHz Out 1 through 5 Connectors

1. Set the signal analyzer reference level to +20 dBm, and the center frequency to 100 MHz.
2. On the SFP, under 100 MHz Reference, enable (check) Out 1 through 5 Enabled.
3. On the SFP, under External Reference, uncheck Use External Reference.
4. Connect the RF INPUT on the signal analyzer to the 100 MHz Out 1 connector on the M9300A.
5. The output level should be $\geq +10$ dBm.
6. Measure the power out of 100 MHz Out 2 through 5 for $\geq +10$ dBm.
7. On the SFP, disable (uncheck) 100 MHz Reference Out 1 through 5.
8. Repeat the measurement of power on 100 MHz Reference Out 1 through 5.
9. The power level should be ~ 20 dB less than measured when the outputs were enabled.
10. If any power level fails (when enabled or disabled) the Reference module needs to be repaired. See [Return a Module for Service](#) .

10 MHz Out, 100 MHz BP Out and OCXO Out Connectors

1. On the SFP, under Other References, select and enable 100 MHz BP Out, 10 MHz Out and OCXO Out.
2. Set the signal analyzer center frequency to 10 MHz, reference level to 20 dBm and span to 1 kHz.
3. Connect the signal analyzer to 10 MHz OCXO Out.
4. Verify that the 10 MHz OCXO power level is $\geq +9$ dBm.
5. Connect the signal analyzer to the 10 MHz Out connector and verify that the power is $\geq +7$ dBm.
6. Set the signal analyzer center frequency to 100 MHz and the span to 50 kHz.
7. When the 10 MHz Out and OCXO Out controls are Enabled and there is no or low signal present, the module is defective and needs to be repaired. See [Return a Module for Service](#) .
8. Connect the spectrum analyzer to the 100 MHz BP Out connector and verify that the power is $\geq +10$ dBm.

9. If the power level is low, the module is defective and needs to be repaired.
See [Return a Module for Service](#) .

M9300A Status LEDs

NOTE

Once you open the SFP, select M9300A, and then choose **Connect**. The module is initialized. Until a module is initialized, the LEDs are off. If no modules are visible in the SFP "Connect to Instrument" dialog, see [M9300A PXIe Frequency Reference Module Troubleshooting](#) .

Module	Green	Orange	Red	Off
M9300A	Indicates the SFP has initialized the connection to the module	n/a	Indicates that the VCXO is unlocked.	<ul style="list-style-type: none">- When not connected by the SFP.- Shows a power supply failure. Module health can't be assured until the failure is resolved.



This information is subject to change
without notice.

© Keysight Technologies 2014 - 2016
Edition 2, November, 2016

Printed In USA



M9300-90001

www.keysight.com